

Tubos Cuadrados

ASTM A-554

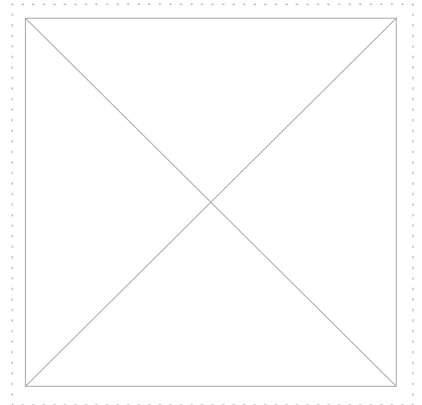

Corte Axial
Pieza Completa

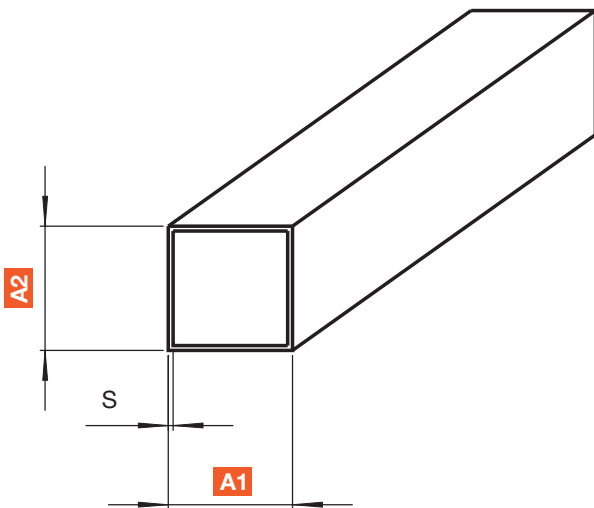

Denom.	A1	A2	S1 mm.	S2 mm.	S3 mm.
10/10	10	10	1.00	1.25	1.50
12/12	12	12	1.00	1.25	1.50
15/15	15	15	1.00	1.25	1.50
20/20	20	20	1.25	1.50	2.00
25/25	25	25	1.25	1.50	2.00
30/30	30	30	1.25	1.50	2.00
35/35	35	35	1.25	1.50	2.00
40/40	40	40	1.25	1.50	2.00
50/50	50	50	1.50	2.00	3.00
60/60	60	60	1.50	2.00	3.00
70/70	70	70	2.00	3.00	-
80/80	80	80	2.00	3.00	-
90/90	90	90	2.00	3.00	-
100/100	100	100	2.00	3.00	-

Calidad
del material

Otra
Descripción

304 - 304L - 316 - 316L

Descripción Técnica

