

Tubos

ASTM A-269/A-270/A-554

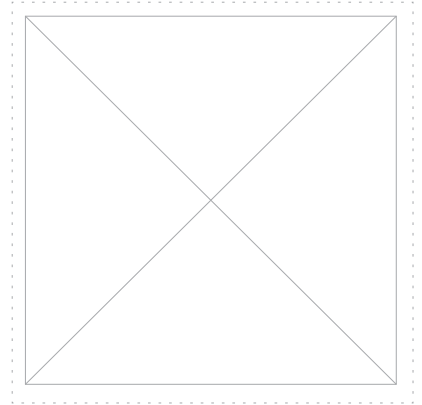

Corte Axial
Pieza Completa

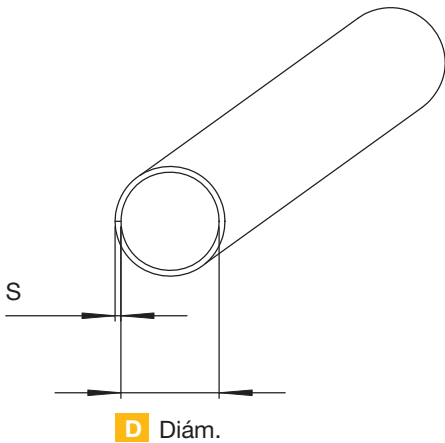

ϕ D pulg.	D	S1 mm.	S2 mm.	S3 mm.	S4 mm.
1/2"	12.7	0.80	1.00	1.25	1.50
5/8"	15.8	1.00	1.25	1.50	2.00
3/4"	19.05	1.00	1.25	1.50	2.00
7/8"	22.2	1.00	1.25	1.50	2.00
1"	25.4	1.00	1.25	1.50	2.00
1 1/8"	28.6	1.00	1.25	1.50	2.00
1 1/4"	31.8	1.00	1.25	1.50	2.00
1 1/2"	38.1	1.00	1.25	1.50	2.00
1 3/4"	44.5	1.25	1.50	2.00	3.00
2"	50.8	1.25	1.50	2.00	3.00
2 1/2"	63.5	1.25	1.50	2.00	3.00
3"	76.2	1.50	2.00	3.00	4.00
4"	101.6	1.50	2.00	3.00	4.00
5"	127.0	2.00	2.50	3.00	4.00
6"	152.4	2.00	2.50	3.00	4.00
8"	203.0	2.00	2.50	3.00	4.00
10"	254.0	2.00	2.50	3.00	4.00

Calidad
del material

Otra
Descripción

304 - 304L - 316 - 316L

Descripción Técnica

